

Autocollimators and Accessories

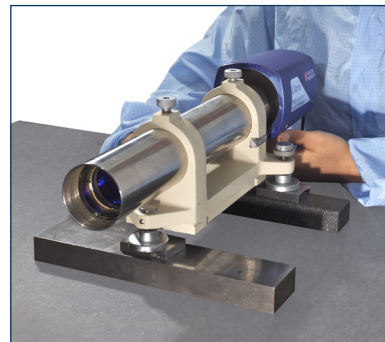

Measuring angle, straightness, flatness,
squareness & parallelism

The Autocollimator range

For measuring angle, straightness, flatness, squareness and parallelism

Used extensively in workshop, tool rooms, inspection departments and quality control laboratories throughout the world.

Taylor Hobson Autocollimators – developments of the renowned Hilger and Watts products – are sensitive optical instruments designed for the accurate measurement of small angular displacements.

There are a number of models in this comprehensive range, from the simple Minidekkor to the Ultra High Precision Autocollimator.



The principles of autocollimation

Light from an origin point O is collimated (made parallel) by a high quality objective lens. If the collimated beam falls perpendicularly onto a plane reflecting surface, the light is reflected back along its original path and is brought to a focus at a point coincident with the origin point (as Figure A). If the reflector is tilted through an angle θ , the reflected beam is deflected through an angle 2θ , and the image I is displaced laterally from the origin O .

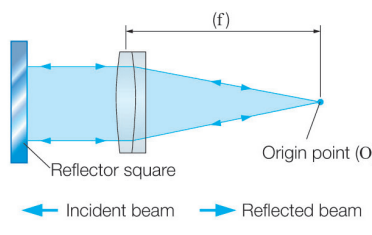

Figure 'A' Reflector square to beam

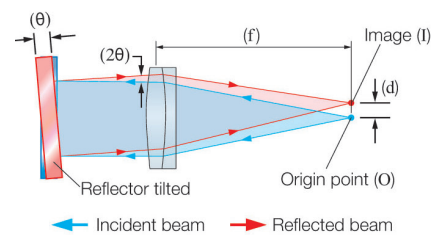

Figure 'B' Reflector tilted to beam

The amount of displacement is given by $d=2\theta f$ where f is the focal length of the lens, and θ is in radians. Given that f is a known constant for the Autocollimator, measurement of the displacement d enables the tilt θ to be ascertained.

An illuminated target graticule is directed towards the objective by a beam splitter. After reflection by a mirror (workpiece) the light returns through the Autocollimator and passes through the beam splitter, forming an image of the target graticule in the plane of an eyepiece graticule.

The eyepiece graticule and the reflected image of the target graticule are viewed simultaneously through the eyepiece. Although the target graticule is always seen in focus and at constant magnification in the eyepiece.

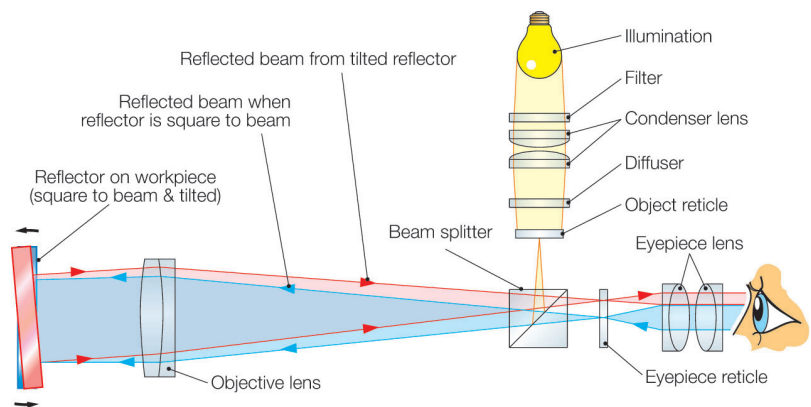

Figure 'C' Operating principle of Autocollimator

At long working distances only a portion of the target graticule appears in the eyepiece, owing to the failure of obliquely returning rays to enter the Autocollimator. This can restrict the measuring range.

Autocollimation in practice

Checking, measuring, indexing & monitoring

Taylor Hobson Autocollimators are used in conjunction with reflecting mirrors or surfaces for the accurate measurement of small angular deviations from a datum angle.

The main advantages of Taylor Hobson autocollimators are:

- High accuracy & wide range angle measurement
- Easy to set up and operate
- Calibration traceable to international standards
- Choice of Visual or Electronic systems
- Wide range of accessories and levels

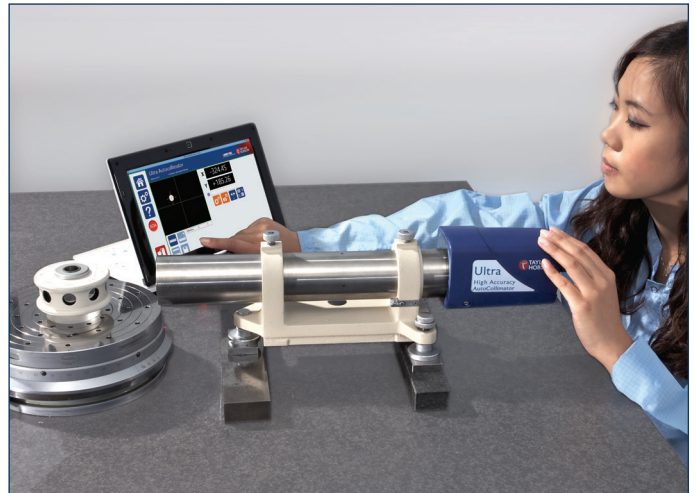

Ultra High Precision Autocollimator with reference index table used to calibrate a polygon

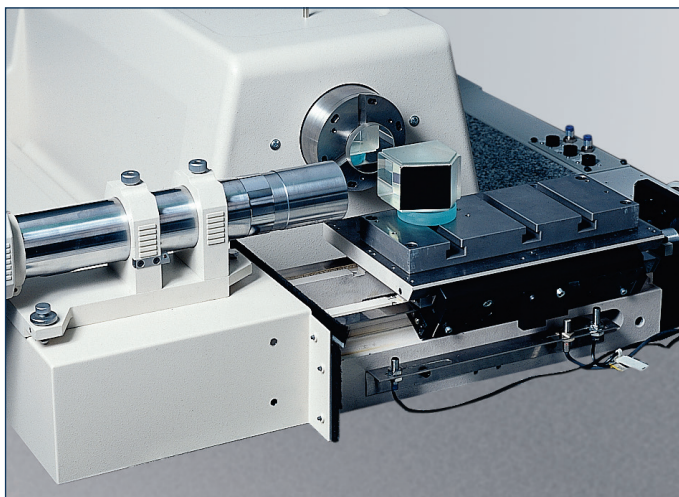

Precision Machine Tool alignment

Their main applications include:

- Checking straightness of machine tool slideways
- Checking dividing heads for their angular displacements
- Measuring very small angles
- Measuring small linear displacements
- Checking flatness of bed plates and surface tables
- Checking squareness of column to base
- Checking parallelism of twin slide rails

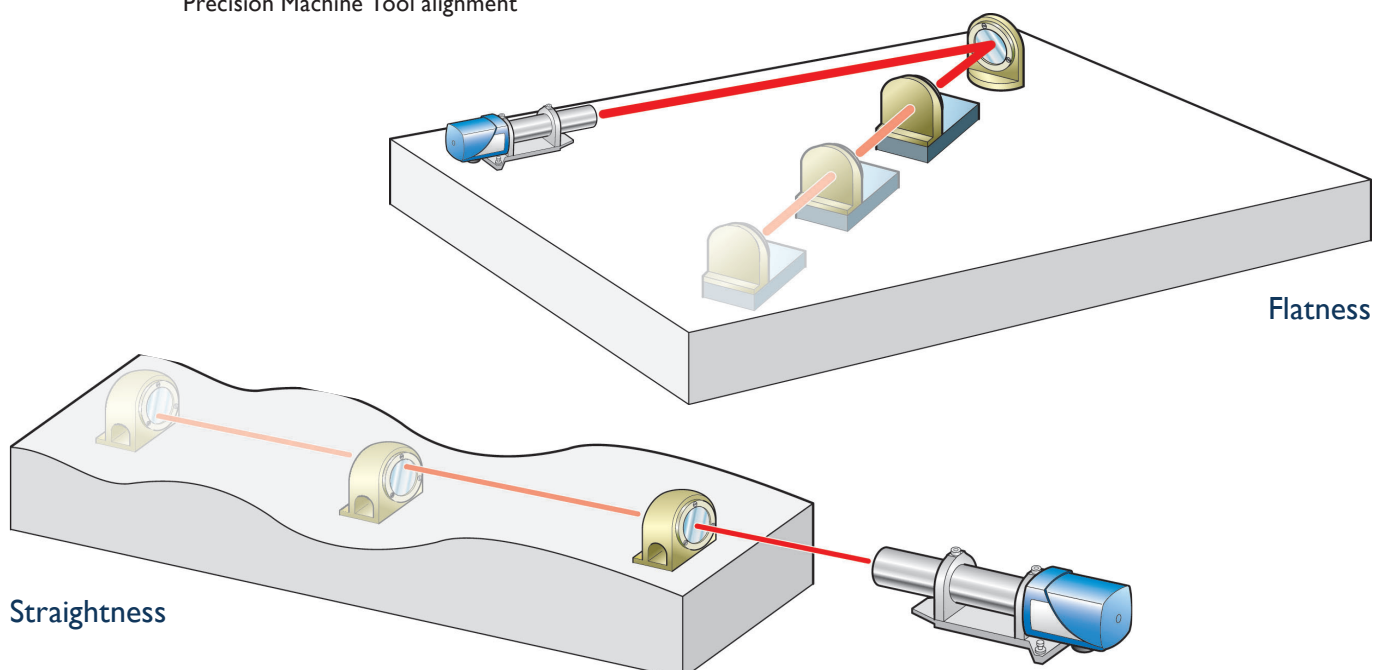

Visual Autocollimators

Flexible, affordable, easy-to-use and read

The visual autocollimators are extremely accurate instruments with a wide variety of applications.

They are normally supplied with the eyepiece positioned for straight through viewing, although the TA51 is available with the eyepiece positioned for right angle viewing if required. Measurements are made using a graticule in the eyepiece viewing system with or without micrometers.

The Taylor Hobson VA900 and TA51 Autocollimators incorporate a micrometer in the eyepiece viewing system for the precise measurements of angular displacement. The TA51 has two micrometers, one in each axis of measurement.

On single axis types, the instrument is rotated through 90 degrees to measure in a second plane.

The micrometer is used to move the eyepiece graticule across the field of view until it coincides with the reflected target graticule image. The angular displacement of the reflector can then be read directly from the micrometer scale.

The TA51 Autocollimator is normally supplied with a light field graticule. Only one setting line is used in instruments fitted with dark field graticules.

The VA900 and TA60 Minidekkor Autocollimators are normally fitted with dark field graticules as standard for a better visual contrast from low reflectivity surfaces or a small reflector. However, light field graticule variants can be supplied on request.

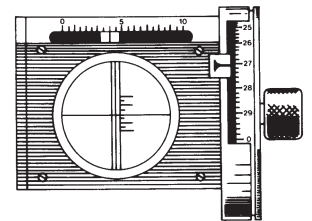

Field of view through eyepiece

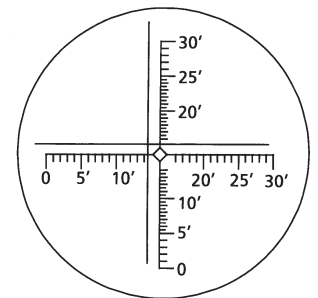

VA900 Graticule

TA60 Dual Axis Minidekkor (code 142-10)

- Affordable, lightweight and portable
- Wide range of measurement
- Can measure X and Y axes at the same time using a graticule
- Can measure components of low reflectivity or with small surface area

The TA60 Minidekkor is an inexpensive visual Autocollimator using a two axes graticule for general measuring duties in workshop and tool room. The standard Minidekkor is provided with a dark field graticule, forming an illuminated cross line image on a dark background. This offers the advantage of clear images being obtained from low reflectivity surfaces such as unsilvered glass, and from surfaces as small as 3 mm (0.125 in) in diameter.

With the addition of a microscope objective and linear measuring device, the Minidekkor can be used for measuring radius of curvature of a lens or mirror and, for example, the spacing of electrodes enclosed in a glass envelope.

This Autocollimator is supplied as standard without mounting fixtures. Therefore, when ordering it is important to consider the applications and select the appropriate mounting accessories.

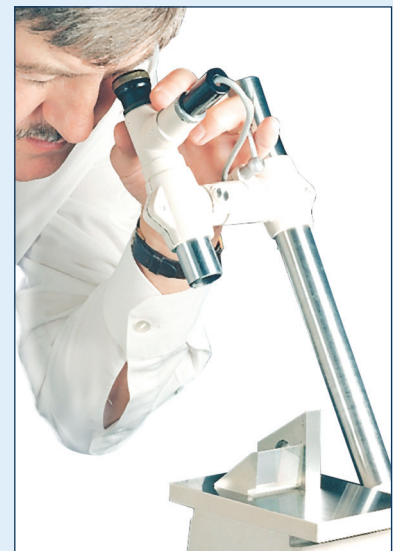

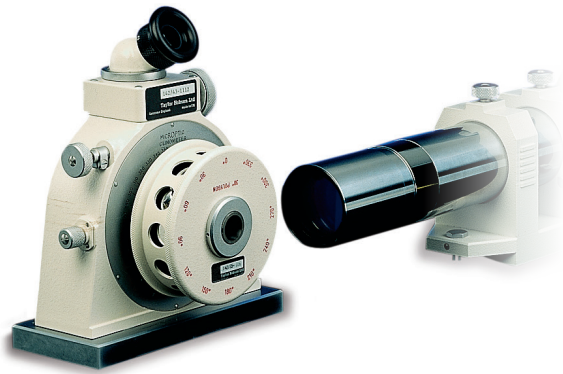

...checking the TB100 clinometer with the TA51 autocollimator

VA900 Microptic Dual Axis Autocollimator

(code 112-2208 / M112-5767)

- Lightweight high accuracy instrument
- Ideal for precise measurement of angle of components such as prisms and for checking straightness, flatness and angular indexing
- Wide range using combination of graticule and micrometer

The VA900 Microptic Autocollimator is a dual axis, lightweight, highly accurate instrument. It is ideally suited for the precise measurement of angles or components such as prisms, for checking straightness, flatness or angular indexing. Measurement of the two axes is made using a combination of the instruments two axes graticule and single micrometer and is provided as standard with a dark field graticule.

This Autocollimator is supplied as standard without mounting fixtures. Therefore, when ordering, it is important to consider the application and select the appropriate mounting accessories.



VA900 Microptic Dual Axis Autocollimator (Shown as as system M112-5767 including vertical base and visual camera system)

TA51 Microptic Dual Axis Autocollimator* (code 142-13)

- High Accuracy and Wide Angle
- Ideal for checking machine slides for straightness and squareness
- Checking flatness of surface tables
- Checking angular indexing tables and polygon

The TA51 is supplied as standard with a light field graticule and comes complete with a levelling base as shown. It is an extremely accurate and flexible system when used in conjunction with the wide variety of accessories shown in this brochure.



Camera Systems for Visual Autocollimators

(code 137-1991)

The visual autocollimator range can be used in conjunction with a high resolution camera in place of an eyepiece. Dedicated Vivi software allows the image to be magnified up to x8, making it easier to view any angle changes precisely and minimising eye strain.

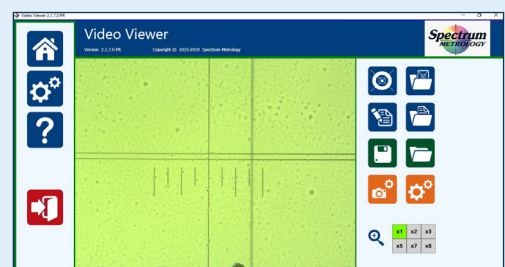

* TA51 Microptic Dual Axis Autocollimator is available with the eyepiece positioned for right angle viewing.

Ultra Series Digital Autocollimators

Dual axis

Using the latest CCD technology the Ultra Dual Axis Autocollimator is a highly versatile instrument offering high accuracy and stability over a range of applications.

Simple set-up

This wide range Autocollimator comes with a laser sighting aid for simple setup. Combine this with the clear visual display on the autocollimators tablet PC and set up is easy even over long distances or with small reflectors.

Clear results

The Ultra Autocollimator also includes as standard the Taylor Hobson dedicated Optical Analysis software which allows advanced measurement, calculation and analysis of a range of features.



Ultra Autocollimator (code 142-201-01)

Key features

- Wide measurement range (1800 seconds)
- High accuracy (0.2 seconds)
- Simultaneous dual axis operation and display
- Laser sighting aid for easy set-up
- Simple touch-screen operation
- Clear software with full electro optics applications package

Applications include:

- Simultaneous 2 axis straightness measurement
- Alignment of optical systems
- Flatness measurement
- Lens centration
- Angles of optical components and prisms
- Checking, setting & measurement of angular indexing heads and tables

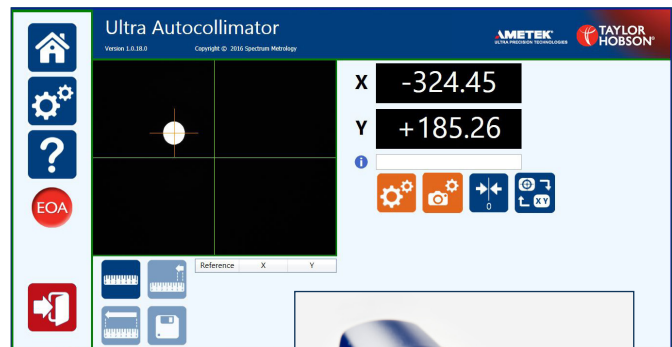

The laser sighting aid attachment and clear visual software in a range of languages ensure that measurement setup is quick and simple.

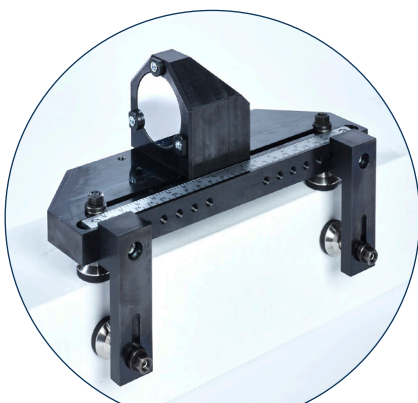

Machine tool slideways

The Ultra autocollimator used with the adjustable base, side feet and mirror allows fast and accurate 2 axis straightness measurement on machine tool slideways.

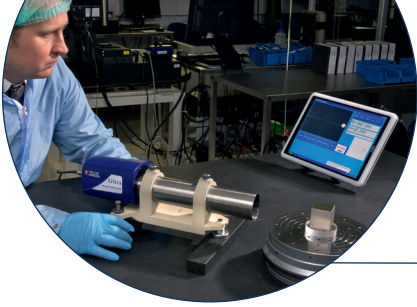

Indexing tables in the lab

Ultra Autocollimator is ideal for measurement of angular indexing heads and tables. It is also commonly used to determine the errors of a polygon when used with a calibrated indexing table.

Ultra High Precision Autocollimator (code 142-204-01)

Key features

- Ultra high 0.1 sec accuracy
- Range of 300 seconds
- Simultaneous dual axis measurement
- Laser sighting aid for easy set up
- Includes software and tablet PC as standard
- Ideal for high precision measurement and indexing of small angles
- Suitable for calibration of polygons, rotary tables and encoders
- Alignment of optical systems

Other variants are available including:

- 142-206 - Long distance (25 m) ultra autocollimator
- 142-213 - Ultra fast autocollimator (100 Hz)
- 142-214 - Ultra Wide range (± 2000 sec)
- Double image systems
- Autocollimators with other wavelengths (e.g 660 nm)



Performance improving software

Dedicated Electro Optics Analysis software is included as standard:

Straightness

This simple interactive icon driven software allows single or simultaneous 2 axis straightness of components such as machine tool slideways, shafting and rolls.

Twist

The twist program allows straightness measurements to be carried out on one guideway and then compared to the straightness of a second guideway (when using a Talyvel levelling system, see the brochure 'Talyvel/Clinometers For Angular Measurement').

Polygon & Enhanced Polygon

This program is designed specifically for the calibration of rotary devices and polygons with up to 72 faces, allowing single or bi-directional calibration with results of both angular indexing accuracy and pyramidal error.

Flatness

The Union Jack/Moody method for flatness measurement uses operator selected measuring steps to measure each generator line and calculate the overall flatness of the surface.

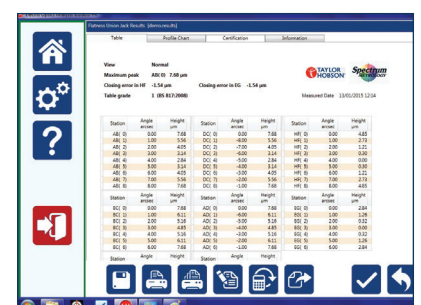
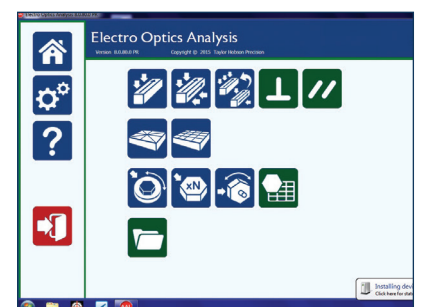

Application:

Two axis straightness, squareness, parallelism and twist measurement of machine tool slides

Among the large number of applications possible with the Taylor Hobson Ultra Dual Axis Autocollimator, the most common is the simultaneous two axis straightness measurement of machine tool slideways.

Typically a ten metre slide can be checked in approximately five minutes – a considerable reduction in the amount of time taken compared with more conventional methods.

The supplied PC also has Taylor Hobson applications software pre-loaded at no extra cost, for computerised measurement of straightness, parallelism, squareness and twist with printouts of measured results available.

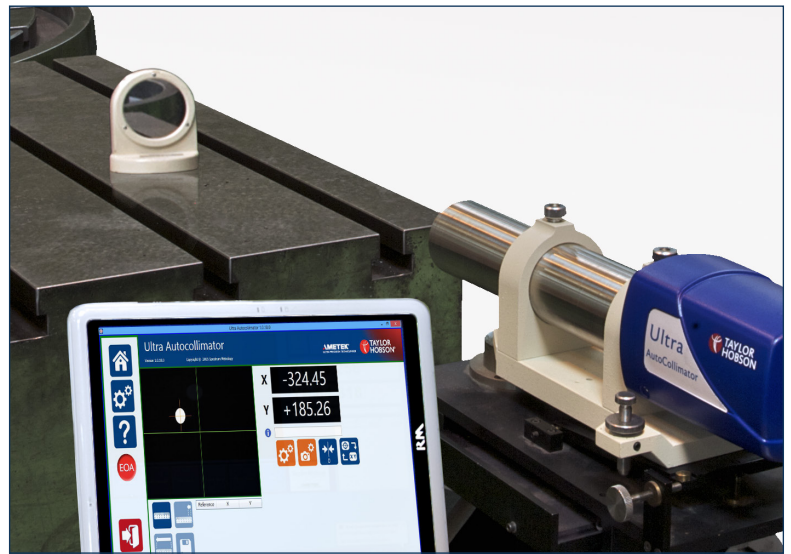

Measuring procedure

Due to the high sensitivity of the autocollimator and the high accuracy with which measurements are made, the autocollimator is usually mounted directly onto the machine slideway.

This is best accomplished using a bracket, rigidly bolted to the end of the slide. If this is not possible the autocollimator can be placed directly on the slide.

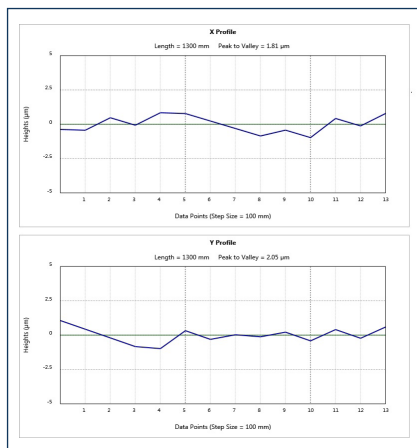

The reflector to be used in conjunction with the autocollimator is mounted onto a carriage, specifically designed for dual axis measurement.

The steps along the slideway must be of equal distance therefore the number of steps to be taken will depend on the base length of the reflector carriage and the length of the slideway.

Any out-of-straightness in either of the two surfaces (side and top of the slide) will cause the carriage to change angle with respect to the autocollimator, and it is these changes which are measured and computed automatically to determine the error in straightness.

The out of straightness is the maximum peak to valley and can be calculated using either the ends zero, least squares or minimum zone method (selectable within the software).

In addition, the slope of the slideway with respect to the autocollimator is displayed as a gradient (ie mm per m or 0.001in per inch). This is derived from a least squares mean line calculated from the data. This slope can be particularly valuable when measuring parallelism and squareness between slideways.

A Talyvel® Electronic Level is used in conjunction with the Ultra Autocollimator to measure the twist or roll of the slideway and an optical square is used for parallelism and squareness checks.

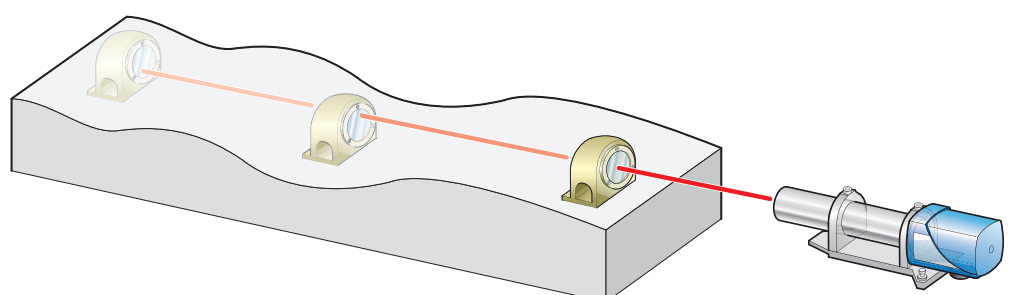

Application:

Parallelism of twin rails

This is a common application which can be solved by using an autocollimator together with an optical square and mirror.

Firstly the autocollimator is positioned and set up with the optical square to measure the first rail. The autocollimator can be mounted on trivets, tripods or heavy duty stands and the reflector is moved along the first rail and a series of straightness measurements can be taken and the slope value calculated (using the Taylor Hobson Electro Optics Analysis software).

Leaving the autocollimator in the same position, the optical square and reflector are then moved to the second rail and the measurements repeated.

The addition of a Talyvel® electronic level (M112-4515) on an adjustable base (112-5592) with optical square (142-77) allows parallelism to be set and checked in 2 axes.

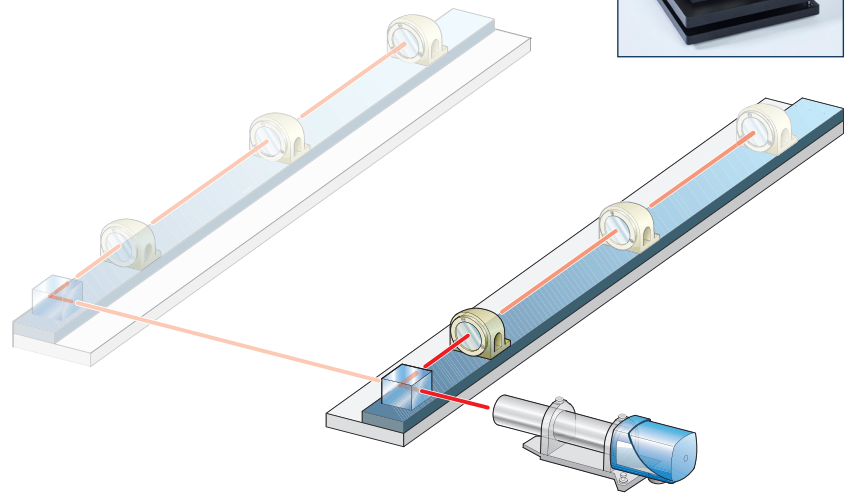
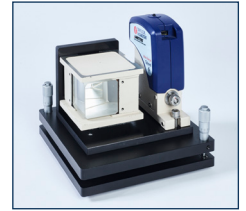

Note: It is imperative that the autocollimator is not moved from the first rail position as this is the reference line. The out of squareness (parallelism) between the two rails is the difference in the individual slope values.

Application:

Checking indexing head and polygons

Modern machining systems use rotary tables for tilting and indexing the part. The rotary table's positioning accuracy is an integral part of system accuracy.

When used to measure angular errors of rotary tables an autocollimator measures the deviation from nominal angle determined by the angular master. The angular master is usually a precision polygon mirror or an index table.

Uniquely the autocollimator's accuracy is not influenced by breaking the light beam, making it a very practical device to use.

Polygon

Although polygons are available with as many as 72 faces, those used for rotary tables typically have 8, 12, or 16 faces. The polygons are regular; that is the angle between the faces is equal. Since polygons are not perfectly regular a list of deviations is supplied in the form of a calibration chart.

To ensure proper alignment, the polygon is mounted on the rotary table using the inside diameter of the polygon as a reference. The inside diameter centreline is parallel to the faces and square to the base. After alignment, one of the mirror faces on the polygon is rotated toward the autocollimator and zeroed; then the rotary table readout is zeroed.

During inspection the table is rotated until its readout is the nominal angle of the polygon (45 degree increments for an eight-sided polygon). This next face should be aligned to the autocollimator. If it isn't, the error can be read on the autocollimator. The table should be rotated to each face of the polygon until all positions are inspected. At zero degrees, the table should return to zero deviation.



An alternative to the polygon is a precision indexing table. To use an index table, a plane mirror is placed on the centre of rotation and parallel to the axis of rotation. The index table is aligned in the same manner as a polygon. During inspection the rotary table is rotated to 23 degrees, for example, and the index table is counter-rotated 23 degrees. If the mirror isn't aligned, again, the error can be read on the autocollimator.

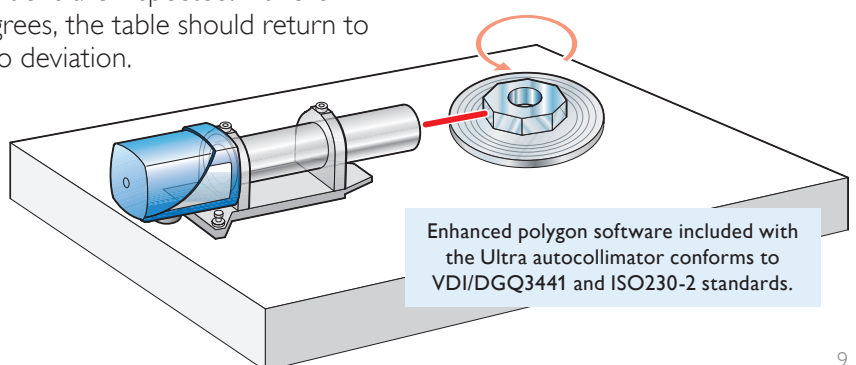

Enhanced polygon software included with the Ultra autocollimator conforms to VDI/DGQ3441 and ISO230-2 standards.

Accessories

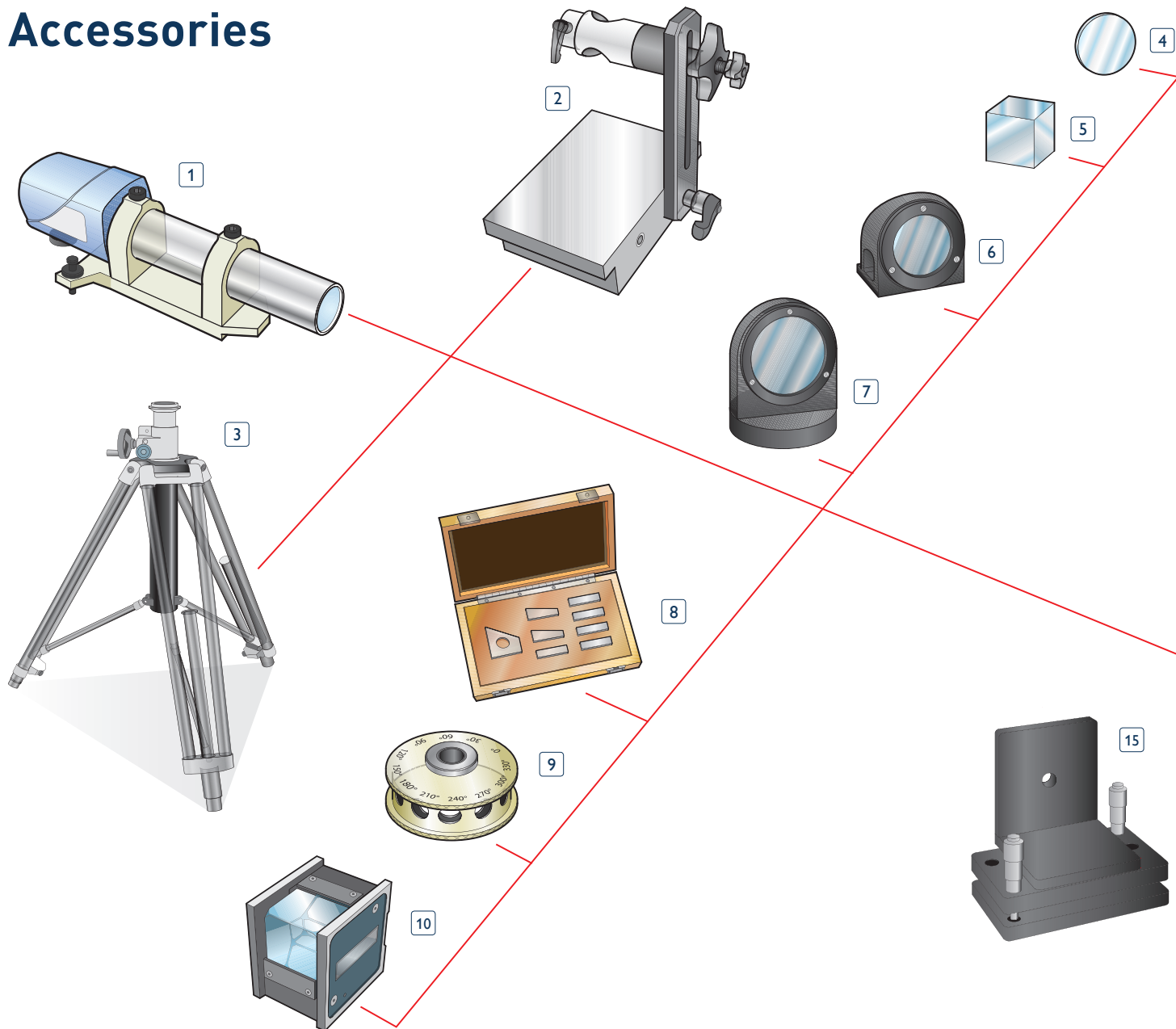

Adaptor plate (112-4947) shown on tripod



Vertical Base with bracket (112-3451/112-3450) and Levelling base (K501-3341)

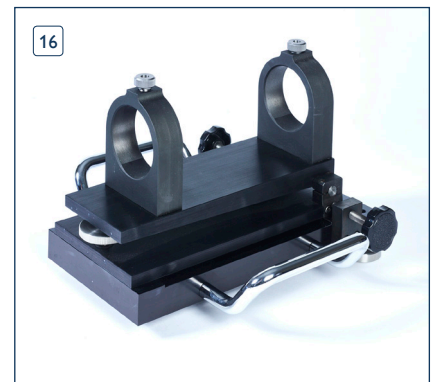

Azimuth base (112-4946)

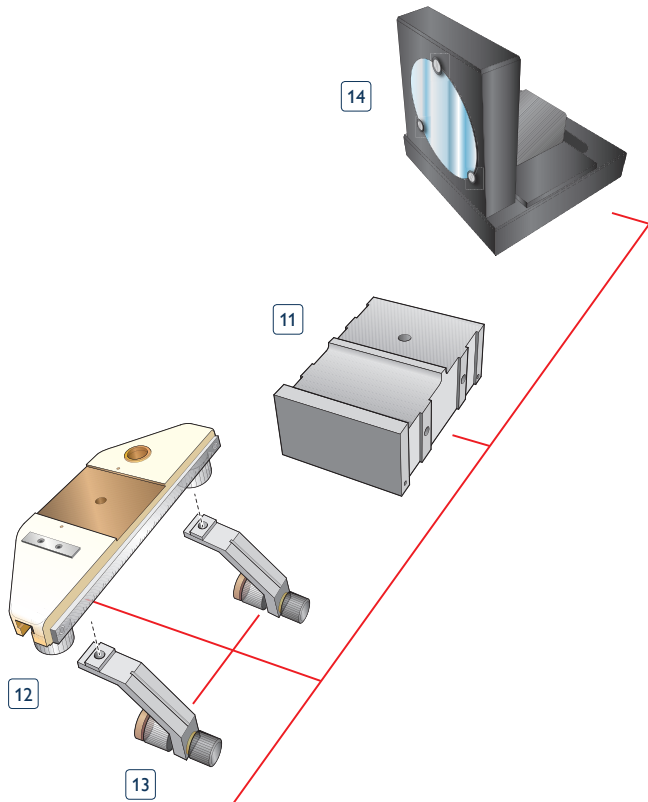

| | | |
|----|---|--|
| 1 | Autocollimator | |
| 2 | Vertical Base with Adjusting Bracket | 112-3451-01 (TA60) 112-3450-01 (VA900) On request (Ultra/TA51) |
| 3 | Tripods stands or trivets | On request |
| 4 | Unmounted 50 mm glass reflector | On request |
| 5 | 38 mm Glass Cube Reflector | 142-25 |
| 6 | Standard 50 mm Glass Reflector | 142-24 |
| 7 | Large Glass Reflector | 142-26 |
| 8 | Box of Angle Gauges | 142-32 |
| 9 | 12 sided Polygon (up to 72 sided polygons available on request) | 142-35 |
| 10 | Optical Square | 142-77 |
| 11 | Fixed Base for 142-24 | Various* |
| 12 | Adjustable Base | 112-2316 or 112-5826 |
| 13 | Side Feet | 137-1947 or 112-5827 |
| 14 | Reflector with magnetic base | 112-5591 |
| 15 | Adjustable table for optical square | 112-5439 |
| 16 | Azimuth base | 112-4936 |

Levelling bases and stands

1 Levelling base

Included as standard with Autocollimators TA51 and Ultra series.

The levelling base provides support for the Autocollimator, enabling the unit to be levelled and to bring its axis parallel to the surface being measured. It incorporates clamps to securely hold the Autocollimator without damage.

- Spacing between front and back foot screws: 205 mm (8 in)
- Spacing between the two back foot screws: 130 mm (5 in)
- Height of Autocollimator axis when base is resting on the pads: 76 mm (3 in) without pads: 67 mm (2.5 in)
- Range of angular adjustments: approx $\pm 3^\circ$
- Approximate weight: 3.4 kg (7.5 lb)

code K501-3341

3 Tripod

Adjustable tripod up to 1.4 m (other models available). Used with adaptor plate (112-4947) to hold Ultra Autocollimator.

code 112-4942

Adaptor Bushes

A set of two bushes to convert standard levelling bases (K501-3341) to 38 mm (1.5 in) diameter for use with VA900.

code 112-2257

16 Azimuth Base

To give $\frac{1}{2}$ degree fine adjustment of azimuth elevation on Ultra and TA51.

code 112-4946

2 Vertical Base with Adjusting Bracket

A multipurpose stand of sturdy construction for general bench use, comprising epoxy granite surface plate, and ground cast iron column and bracket. The Autocollimator clamping bracket has independent clamping and rotational adjustments, enabling the bracket to be turned without disturbing the height adjustment.

- Available for use with 25.4mm (1 in), 38 mm (1.5 in) and 57 mm (2.25 in) diameter autocollimators.
- Surface Plate Area: 220 x 150 mm (8.7 x 5.9 in)
- Maximum Height Adjustment above Surface Plate: 200 mm (8 in)
- Flatness of Surface: 5 μ m (0.0002 in)
- Approx Weight: 7.6 kg (16.8 lb)

code 112-3451

- TA60, 25.4 mm (1 in) dia. clamp

code 112-3450

- VA900, 38 mm (1.5 in) dia. clamp

* 100 mm base (112-4948), 200 mm base (112-4949), 100 mm magnetic base (112-5437) & 200 mm magnetic base (112-5438)

Accessories

Straightness & flatness measurement

6 Standard glass reflector 50 mm (2 inch)

A reflector is an integral part of any Autocollimator system. Successful autocollimation requires a reflector of adequate flatness, reflectivity and diameter; this reflector meets all of these requirements. Steel reflectors and unmounted versions can be supplied to special order.

Also available with a double sided reflector (112-5467) or as a single sided adjustable reflector (112-5468).

- Diameter: 50 mm (2.0 in) nominal
- Faces Parallel to Within: 5 secs
- Faces Flat to Within: 0.1 μm (3.8 μin)
- Centre height of Mounted Reflector: 37 mm (1.5 in)
- Weight Unmounted: 130 g (9 oz)
- Mounted: 1.1 kg (2.5 lb)

code 142-24 (mounted)

11 Fixed base for 142-24

Fixed reflector carriage used to mount reflector (142-24). Magnetic versions are also available (112-5437 - 100 mm and 112-5438 - 200 mm).

code 112-4948 (100 mm)
code 112-4949 (200 mm)

7 Large glass reflector mounted 80 mm (3 inch)

Offering a large reflective surface, this is normally used together with a reflector carriage and mounted reflector (142/24) for calibrating a surface plate. It enables several calibration lines to be traversed without the Autocollimator being moved, thereby saving setting up time.

code 142-26

16 Large glass reflector with On/Off magnetic base

This large mirror is mounted securely to a machine tool carriage for straightness checks with the aid of an On/Off magnetic base. 110 mm length - longer lengths available on request.

code 112-5591

12 Adjustable base

This accessory has a 200 mm (8 in) range of adjustment and can be set to the appropriate step interval length for flatness and straightness measurement. It provides a base for the reflector (142/24) with self aligning seating pads adjustable to a graduated scale. This base can also be used for mounting a Talyvel® level unit. Fixed bases can be supplied on request.

code 112-2316 (Standard)
code 112-5826 (Simple)

13 Side feet

For use with the Adjustable Base when measuring in two axes.

code 137-1947 (for use with 112-2316)
code 112-5827 (for use with 112-5826)

Squareness & parallelism measurement

10 Optical square

- Aperture: 38 mm (1.5 in) 90° angle accurate to within ± 1 sec

This square comprises a mounted pentagonal prism and is used to deviate the autocollimator beam through 90°.

It may be used when checking the straightness of two surfaces which are at right angles to one another or when checking parallelism. A lower specification version is available, ± 3 sec (142-212). Adjustable base is available (112-5439).

code 142-77

5 Cube reflector

Can be used as general purpose reflector and for providing a 90° angle standard in three planes, for setting or checking perpendiculars.

- Size of Faces: 38 mm (1.5 in) square
- Reflector Faces: 3 (2 adjacent faces perpendicular to the base, 1 parallel to the base)
- Accuracy of 90° Angle: ± 3 secs
- Weight: 0.43 kg (1 lb)

Other cubes can be supplied to required specifications to special order. For example, as above but with an accuracy of 90° ± 1 sec or with four or five reflective faces.

code 142-25

15 Adjustable table for optical square and/or Talyvel®

Allows the optical square/Talyvel® electronic level to be mounted for use in squareness and parallelism checks.

code 112-5439 (optical square)
code 112-5592 (optical square/Talyvel®)



Reflector mounted on adjustable base (112-5826) with side feet (112-5827), for two axis straightness measurement

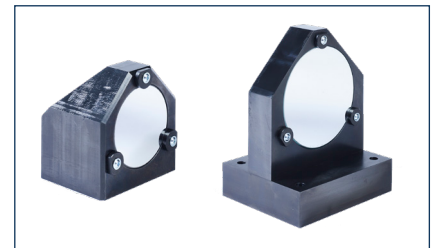

Reflectors (left - 142-24, right - 142-26)

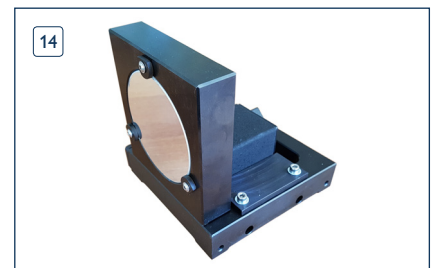

Flat reflector with magnetic base (112-5591)

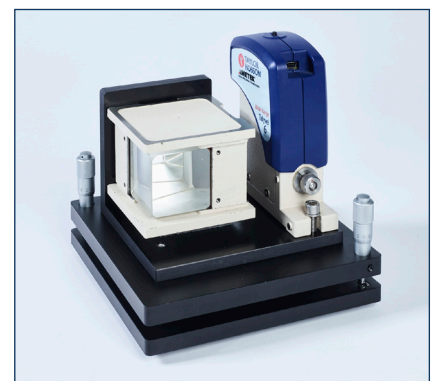

Adjustable table for optical square and Talyvel® (112-5592)

Indexing table, polygon & angle calibration

9 Polygon, 12 sided glass, nominal face angle 30°

The angle between the 0° datum face and any other face is within 5 seconds of the nominal values. A calibration chart is provided with each polygon, giving the actual angles to 0.1 second of arc to an accuracy of determination of 1 second.

A simple adjustable table (112-5632) is available for tilt adjustment when carrying out indexing table measurement.

Other polygons up to 72 sides and in steel or chrome carbide can be supplied to special order.

code 142-35

8 Angle Gauges (Set of 15)

- Gauge Angle – precision square, 45°, 30°, 15°, 5°, 3°, 1°, 30 min, 20 min, 15 min, 10 min, 5 min, 3 min, 1 min, 30 sec, 12 sec, 6 sec
- Accuracy of Angle: ±2 seconds

These gauges can be wrung together additively or subtractively to form most angles from 0° to 90° as a comparison standard. The faces themselves can be used as a reflector.

code 142-32

Software

Remote keypad

Suitable for use with Ultra Autocollimators to trigger measurements remotely.

code 265-1277

CCTV accessory

CCTV System

A miniature CCTV camera can be fitted to the eyepiece of the visual autocollimators when working in awkward locations or simply to reduce eye fatigue. By viewing the image on the laptop screen, the image can be magnified and a number of operators can view the image if required.

code 137-1991

Test equipment

Fixed Test Wedge

The fixed wedge can be used to quickly check the accuracy of any Autocollimator. It introduces a fixed angle of deviation nominally of 60 seconds by rotating the wedge from minimum to maximum deviation and comparing this with the readings on the Autocollimator. A UKAS certificate is optionally available.

- Centre Height: 75mm (3 in)
- Weight: 1 kg (2.25 lb)
- Working Diameter: 50 mm (2 in)

code 137-1940

Digital Angle Generator

Autocollimators require periodic calibration to verify their capability for precise measurement. Users can calibrate their own Autocollimators using a Small Angle Generator. This device is also suitable for testing angle gauges, electronic levels, level vials used in block levels etc. A high precision version is also available.

Details available on request



Set of angle gauges (142-32)



12 sided polygon (142-35)



CCTV system (137-1991) shown on VA900 autocollimator and base

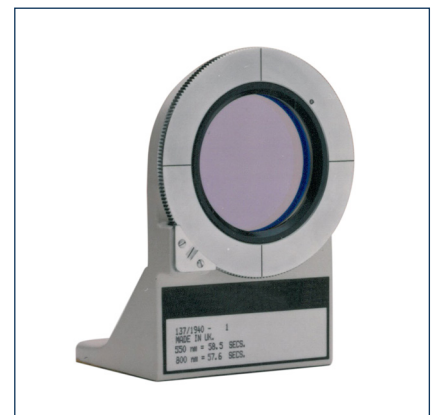

Fixed test wedge (137-1940)

Automatic Prism & Polygon measurement system

High stability angle measurement and testing of optical prisms, polygons, wedges and angle gauges.

In order to be used successfully in most applications, prisms must be manufactured with very strict tolerances and accuracies. Most high precision prisms tend to be made in small batches, each batch varying in shape, size, and number of surfaces.

This measurement system comprises of the digital Ultra Autocollimator; rotary stage and dedicated, simple to use software with improved error correction facility.

The ultra autocollimator uses the latest digital technology to produce a 2 axis, high accuracy (0.2 sec) stable instrument over a wide range (1800 seconds).

The dedicated software allows programmes to be written, saved and recalled using a simple, step-by-step process with results produced in a detailed report format, giving all X and Y data/results ready for visual analysis or export into .csv format for further analysis.

The accuracy of the system is further improved using an error separation technique, which corrects the tables built in encoder systems.

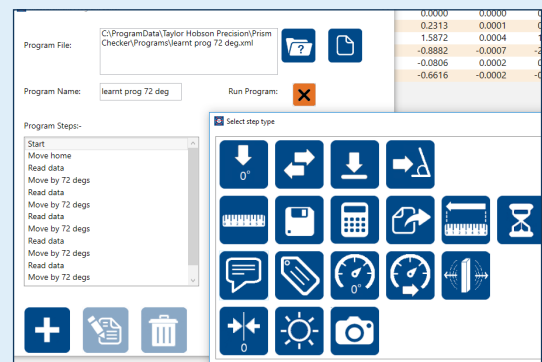
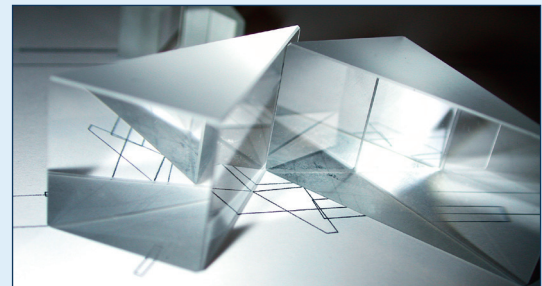

The Taylor Hobson prism checker measures a range of optical prisms, polygons, wedges and angle gauges from as little as 2 mm² in size

- **Measuring Range:** 360°
- **Overall system accuracy (single measurement):** ±0.5 arc sec
- **Resolution of the autocollimator:** 0.001 arc sec
- **Autocollimator aperture:** 40 mm
- **Autocollimator field of view:** 1800 arc sec
- **Autocollimator focal length:** 300 mm
- **Uncertainty of reading on any measured face in the X-axis:** Maximum ±0.5 arc sec
- **Uncertainty of reading on any measured face in the Y-axis:** Maximum ±1 arc sec (pyramid error)
- **Operating temperature:** 20°C ±10°C
- **Minimum surface area (glass uncoated):** 5 mm²
- **Maximum sample size:** 250 mm
- **Maximum sample weight:** 4 kg
- **Table diameter:** 120 mm
- **Base dimension without PC:** 700 x 400 mm
- **Weight:** 60 kg

Checking a polygon

Polygons used for checking indexing tables and heads are typically 8, 9 or 12 sided although they can be supplied with as many as 72 faces. Since polygons are not perfectly regular a calibration chart is supplied to detail the deviations.

“ Taylor Hobson autocollimators have been used by the optics industry since the 1960s for precision angular measurement of optical components, including the range of Hilger & Watts autocollimators which is now integral to the Taylor Hobson range... ”

The Autocollimator range

Specification

| Technical data | | | | | | |
|---|------------------|--------------------------|-------------------|-------------------------------|---------------------|---------------------|
| Type Code | TA60 142-10 | VA900 112-2208 | TA51 142-13 | Ultra 142-201 | Ultra HP 142-204 | Ultra LD 142-206 |
| Best accuracy* | 6 sec | 1 sec | 0.5 sec | 0.2 sec | 0.1 sec | 0.2 sec |
| Accuracy over total range | 30 sec | 1 sec | 2 sec | 0.4 sec** | 0.2 sec** | 0.4 sec**** |
| Range of measurement | min | 60x60 | – | 10 | – | – |
| | sec | – | ± 900 (± 1500ext) | – | 1800x1200 | 300x300 |
| Range in eyepiece | 10,800 sec | 2,800 sec | 1,140 sec | N/A (laser sighting aid used) | | |
| Direct reading to | 60 sec | 0.5 sec | 0.2 sec | 0.001 sec | 0.0001 sec | 0.001 sec |
| Working distance*** for full measuring range | 0.5 m (1.5 ft) | 1 m (3 ft) | 9 m (30 ft) | 5 m (15 ft) | 5 m (15 ft) | 5 m (15 ft) |
| Maximum working distance | 3 m (9 ft) | 5 m (15 ft) | 20 m (60 ft) | 20 m (60 ft) | 10 m (30 ft) | 25 m (75 ft) |
| Readout means | Graticule | Micrometer & raticule | Micrometer | Digital PC Display | | |
| Measurement axes | 2 axes | | | | | |
| Light source for measurement | 6V 2 Watts Lamp | | | Infra-red LED | | |
| Barrel diameter (approx.) | 25 mm (1 in) | 38 mm (1.5 in) | 57 mm (2.25 in) | 57 mm (2.25 in) | 57 mm (2.25 in) | 57 mm (2.25 in) |
| Approximate overall length | 150 mm (6.2 in) | 330 mm (13 in) | 420 mm (16.5 in) | 420 mm (16.5 in) | 490 mm (19.5 in) | 490 mm (19.5 in) |
| Approximate weight | 0.5 kg (1.1 lbs) | 1.7 kg (3.8 lbs) | 4.8 kg (10.5 lbs) | 5 kg (11 lbs) | 5 kg (11 lbs) | 5 kg (11 lbs) |

Specifications are subject to change without notice.

Flexibility to meet your measurement needs

The flexible design of the Ultra Autocollimator allows wider measurement ranges, faster reading rate and higher accuracies to be achieved according to your requirements – prices on application.

* Normally over a centre portion of the range for visual this is the central 60 seconds, for Ultra 800 seconds and for Ultra HP & LD central 100 seconds. Note: the best uncertainty that can be certified by the Taylor Hobson UKAS laboratory is ± 0.2 seconds. Lower uncertainty can be achieved by sending the unit to other international laboratories such as PTB.

** This excludes the outer 30 seconds of the range which can have some degradation.

*** Longer distances may be possible at proportionally reduced range.

**** Over 25 m, estimated range ± 50 sec, accuracy ± 3 sec.

Note: All autocollimators are affected by the condition of the air path between the instrument and the reflector. To obtain maximum accuracy, this must be as short as possible and may need to be shielded from draughts and convection currents.

UKAS Certificate

Autocollimators and certain accessories can be supplied with a United Kingdom Accreditation Service (UKAS) certificate which gives an independent and authoritative traceable guarantee of instrument performance and accuracy. Regular service and UKAS calibration will guarantee that the performance is traceable to International Standards.



The Metrology Experts

Established in 1886, Taylor Hobson is the world leader in surface and form metrology and developed the first roundness and surface finish measuring instruments.

www.taylor-hobson.com

Sales department

Email: taylor-hobson.sales@ametek.com

Tel: +44 (0) 116 276 3771

- **Design engineering** – special purpose, dedicated metrology systems for demanding applications.
- **Precision manufacturing** – contract machining services for high precision applications and industries.

Centre of Excellence department

Email: taylor-hobson.cofe@ametek.com

Tel: +44 (0) 116 276 3779

- **Inspection services** – measurement of your production parts by skilled technicians using industry leading instruments in accord with ISO standards.
- **Metrology training** – practical, hands-on training courses for roundness and surface finish conducted by experienced metrologists.
- **Operator training** – on-site instruction will lead to greater proficiency and higher productivity.
- **UKAS calibration and testing** – certification for artifacts or instruments in our laboratory or at customer's site.

Service department

Email: taylor-hobson.service@ametek.com

Tel: +44 (0) 116 246 2900

- **Preventative maintenance** – protect your metrology investment with an AMECare support agreement.



© Taylor Hobson Ltd. 2019



Taylor Hobson UK

(Global Headquarters)

PO Box 36, 2 New Star Road
Leicester,
LE4 9JQ,
England

Tel: +44 (0)116 276 3771
taylor-hobson.sales@ametek.com



Taylor Hobson France

Rond Point de l'Épine Champs
Batiment D, 78990 Elancourt, France
Tel: +33 130 68 89 30
taylor-hobson.france@ametek.com



Taylor Hobson Germany

Rudolf-Diesel-Straße 16,
D-64331 Weiterstadt, Germany
Tel: +49 6150 543 0
taylor-hobson.germany@ametek.com



Taylor Hobson Italy

Via Della Liberazione 24, 20068, Peschiera
Borromeo, Zeloferamagno, Milan, Italy
Tel: +39 02 946 93401
taylor-hobson.italy@ametek.com



Taylor Hobson India

Divyasree NR Enclave, 4th Floor, Block A,
Plot No. 1, EPIP Industrial Area, Whitefield,
Bengaluru - 560066, India
Tel: +91 80 6782 3346
taylor-hobson.india@ametek.com



Taylor Hobson China

taylor-hobson-china.sales@ametek.com

Shanghai Office

Part A1, A4, 2nd Floor, Building No. 1, No. 526
Fute 3rd Road East, Pilot Free Trade Zone,
Shanghai, 200131, China
Tel: +86 21 5868 5111-110

Beijing Office

Western Section, 2nd Floor, Jing Dong Fang
Building (B10), No. 10, Jiu Xian Qiao Road,
Chaoyang District, Beijing, 100015, China
Tel: +86 10 8526 2111

Chengdu Office

No. 9-10, 10th floor, 9/F, High-tech Incubation
Park, No. 160, Jinyue West Road, Chengdu
610041, China
Tel: +86 28 8675 8111

Guangzhou Office

Room 810 Dongbao Plaza, No.767 East
Dongfeng Road, Guangzhou, 510600, China
Tel: +86 20 8363 4768



Taylor Hobson Japan

3F Shiba NBF Tower; 1-1-30, Shiba Daimon
Minato-ku, Tokyo 105-0012, Japan
Tel: +81 34400 2400
taylor-hobson.japan@ametek.com



Taylor Hobson Korea

#309, 3rd FL, Gyeonggi R&DB Center; 105,
Gwanggyo-ro, Yeongtong-gu, Suwon-si,
Gyeonggi-do, Korea, 16229
Tel: +82 31 888 5255
taylor-hobson.korea@ametek.com



Taylor Hobson Singapore

AMETEK Singapore, 10 Ang Mo Kio Street 65,
No. 05-12 Techpoint, Singapore 569059
Tel: +65 6484 2388 Ext 120
taylor-hobson.singapore@ametek.com



Taylor Hobson Thailand

89/45, Moo 15, Enterprise Park, Bangna-Trad
Road, Tambol Bangkaew, Amphur Bangplee,
Samutprakarn Province 10540, Thailand
Tel: +66 2 0127500 Ext 505
taylor-hobson.thailand@ametek.com



Taylor Hobson Taiwan

10F-5, No.120, Sec. 2, Gongdao Wu Rd.,
Hsinchu City 30072, Taiwan
Tel: +886 3 575 0099 Ext 301
taylor-hobson.taiwan@ametek.com



Taylor Hobson Mexico

Acceso III No. 16 Nave 3 Parque Ind. Benito
Juarez Queretaro, Qro. Mexico C.P. 76120
Tel: +52 442 426 4480
taylor-hobson.mexico@ametek.com



Taylor Hobson USA

27755 Diehl Road, Suite 300, Warrenville,
IL 60555, USA
Tel: +1 630 621 3099
taylor-hobson.usa@ametek.com



1100 Cassatt Road, Berwyn, PA 19312, USA
Email: info.corp@ametek.com
Web: www.ametek.com